

rollyMega Trailer

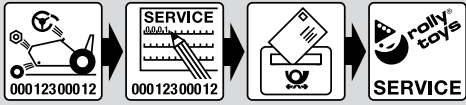
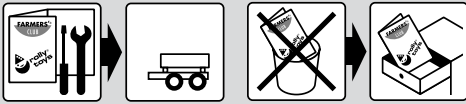
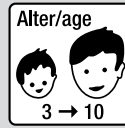

rolly toys Kundendienst Deutschland:

Tel: +49 (0) 95 68 / 856-142
 Fax: +49 (0) 95 68 / 856-183
 e-mail: service@rollytoys.de

2022/02

300.000.800.00

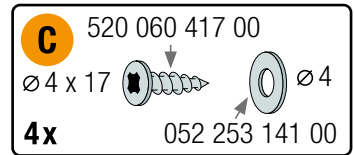
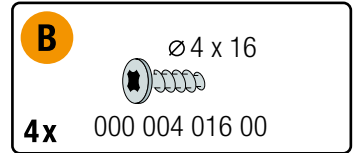
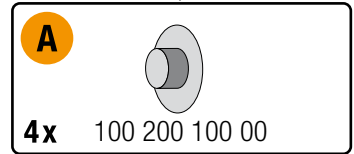
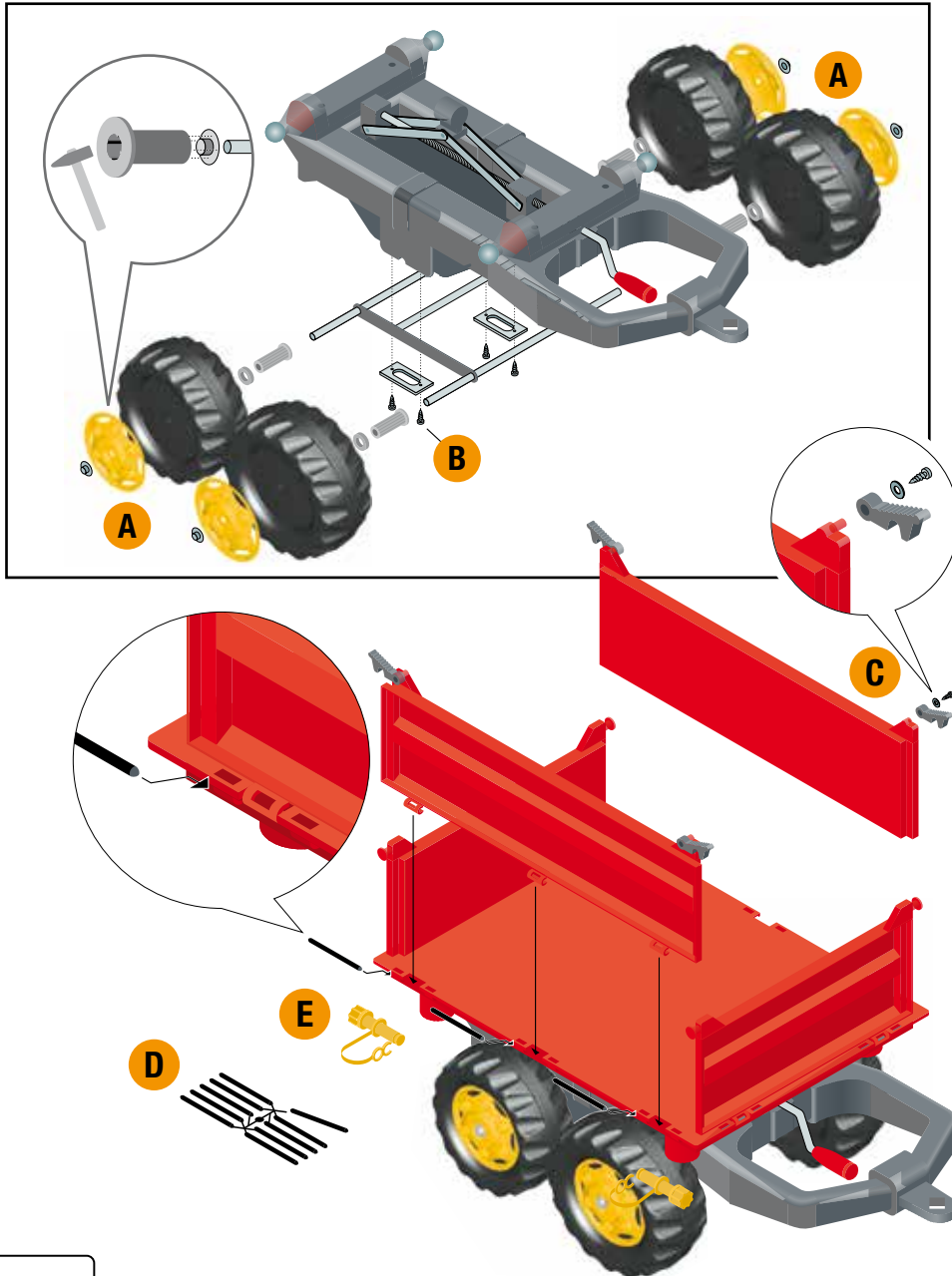

--- NORTH & SOUTH AMERICA only ---

180 days warranty

From the date of purchase + guaranteed spare part service

The warranty does not cover damages caused by improper use or neglect

<input type="checkbox"/>	rolly Dreiradtraktoren 05 ●●●●
<input type="checkbox"/>	rollyMinitrac 13 ●●●●
<input type="checkbox"/>	rollyKid 01 ●●●● / 02 ●●●●
<input checked="" type="checkbox"/>	rollyJunior 80 ●●●● / 81 ●●●●
<input checked="" type="checkbox"/>	rollyFarmtrac 60 ●●●● / 61 ●●●●
<input checked="" type="checkbox"/>	rollyFarmtrac Classic 03 ●●●● / 04 ●●●●
<input checked="" type="checkbox"/>	rollyFarmtrac Premium 70 ●●●● / 71 ●●●●
<input checked="" type="checkbox"/>	rollyX-Trac 03 ●●●● / 04 ●●●●
<input checked="" type="checkbox"/>	rollyTruck (Unimog) 03 ●●●●

made in Germany



Franz Schneider GmbH & Co KG
 P.O.Box 1460
 D-96459 · Neustadt bei Coburg · Germany
 Tel.: +49 (0) 95 68 / 856-0
 Fax.: +49 (0) 95 68 / 856-190
 www.rollytoys.com

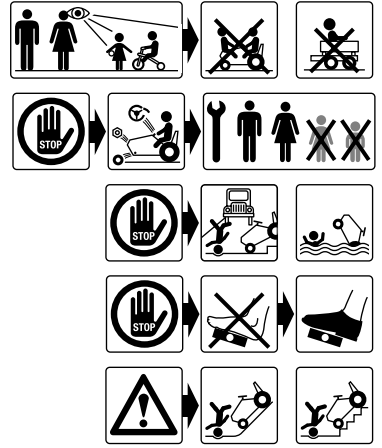
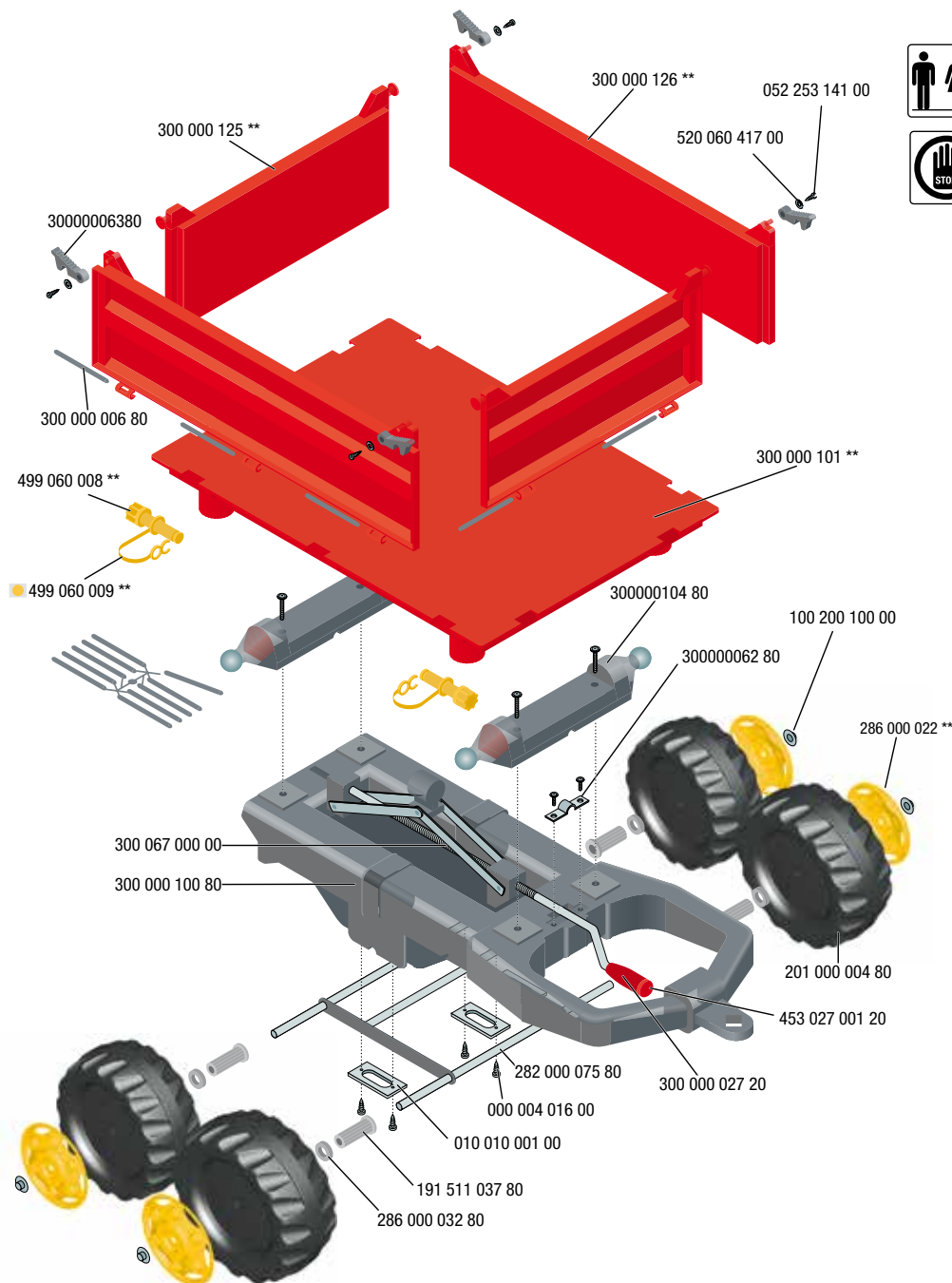

→ **
● +12
● +13
● +20
● +22
● +30
● +37
● +40
● +41
● +44
● +70
● +75

⚠ WARNING:
CHOKING HAZARD – Small parts.
 Not for children under 3 years.

- CHOKING HAZARD - Small parts, Not for children under 3 years.
- Must be assembled by adults
- Adult supervision required.
- Toy is not suitable to carry children.
- If toy is defective stop using it, repairs may only be carried out by adults.
- Never use near steps, slopes, driveways, hills, roadways, alleys or swimming pool areas.
- Always wear shoes.
- The stickers are to be applied by adults only.
- Conforms to the requirements of ASTM Standard Consumer Safety Specification on Toy Safety, F 963.

⚠ AVERTISSEMENT

- RISQUE D'ÉTOUFFEMENT - Petites pièces. Ne convient pas aux enfants de moins de 3 ans.
- Doit être assemblé par un adulte.
- Surveillance d'un adulte est requise.
- Le jouet ne convient pas au transport des enfants.
- Si le jouet est défectueux, cessez de l'utiliser. Toute réparation ne doit être effectuée que par un adulte.
- Ne jamais utiliser à proximité des marches, des pentes, des allées, des collines, des routes, des allées ou des piscines.
- Portez toujours des chaussures.
- Les autocollants ne doivent être appliqués que par des adultes.
- Conforme aux exigences de la norme internationale ASTM Standard Consumer Safety Specification on Toy Safety, F 963.